

PART NUMBER: GA-077

1 SCOPE

This specification covers the dielectric antenna for **700~1000MHz NB- IOT** application.

2 Name of the product

This product is named "Dielectric Antenna".

3 Electrical characteristics

3-1 Electrical characteristics of antenna

The antenna has the electrical characteristics given in Table 1 under the Chinmore standard installation conditions shown in the figure of Evaluation Board.

Table 1

No	Parameter	Specification	
1	Working Frequency	700~1000 MHz,	
2	Dimension	37×5×5 mm	
3	VSWR	5 max (depends on the special environment)	
4	Polarization	Linear	
5	Impedance	50 Ω	
6	Operating Temperature	-40~85°C	
7	Termination	Ag (Environmentally-Friendly Pb Free)	
8	Efficiency(%)	700 MHz	40
		800 MHz	60
		900 MHz	50
		1000MHz	40

* Evaluation board size 45x120 mm.

* Actual Electrical value will depend on customer ground plane size.

S11 Response curve

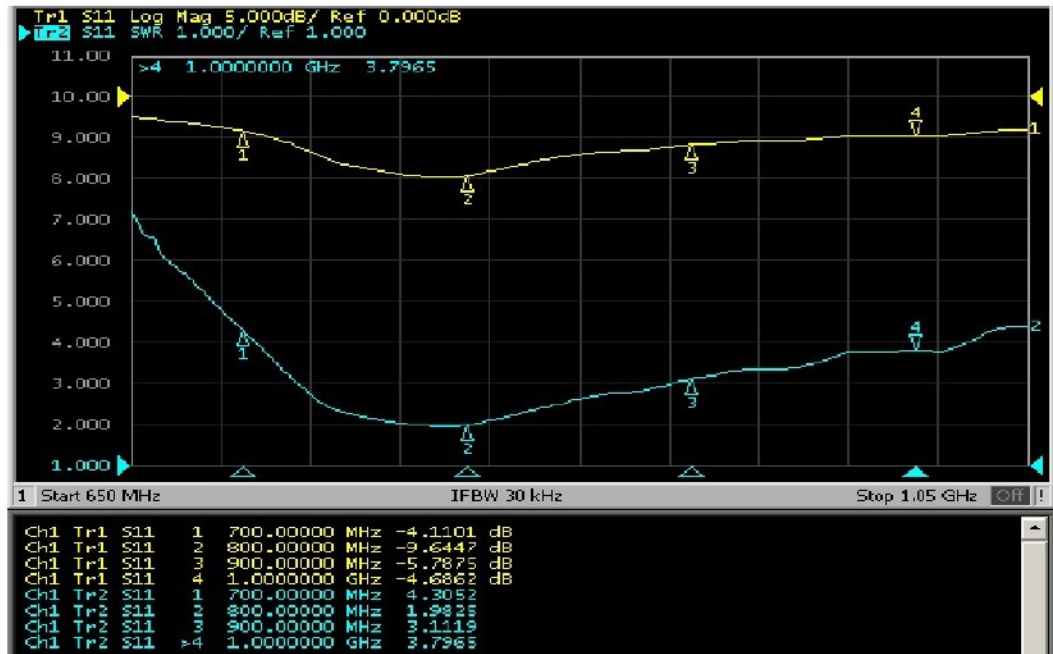

Frequency (MHz)	700	800	900	1000
Return Loss (dB)	-4.11	-9.64	-5.76	-4.68
VSWR	4.30	1.98	3.11	3.79

Gain and Efficiency

(Ground length: 107mm)

NB-IOT Antenna parameter Summary				
Frequency (MHz)	700	800	900	1000
Efficiency (%)	41.82	60.47	50.53	41.76
Average Gain(dBi)	-3.78	-2.18	-2.96	-3.89

NB-IOT Efficiency (%)

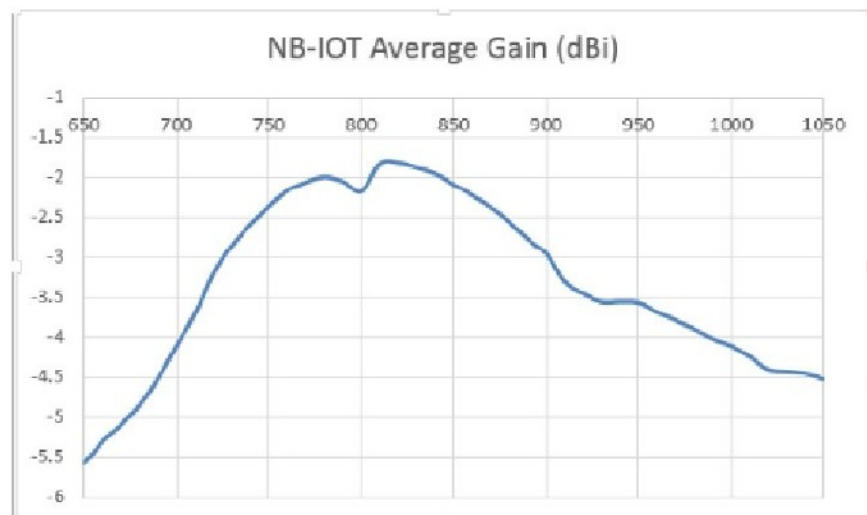
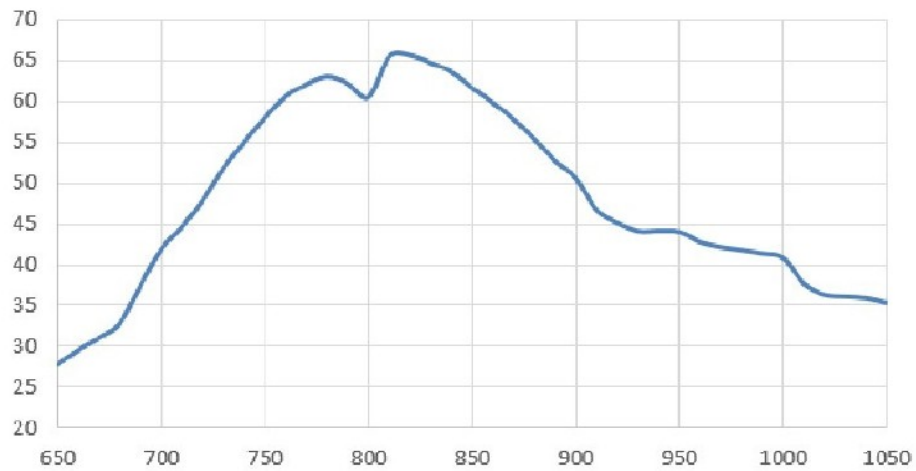

4 Environmental conditions

4-1 Operating conditions

The antenna has the electrical characteristics given in Tables 1 in the temperature range of -40°C to $+85^{\circ}\text{C}$ and under the environmental conditions of $+40^{\circ}\text{C}$ and 0-95% r.h..

4-2 Storage temperature range

The storage temperature range of product is -40°C to $+85^{\circ}\text{C}$

5 Reliability tests

5-1 Low-temperature test

Expose the specimen to -40°C for 16 hours and then to normal temperature/ humidity for 24 hours or more. After this test, examine its appearance and functions.

5-2 High-temperature test

Expose the specimen to $+85^{\circ}\text{C}$ for 16 hours and then to normal temperature/ humidity for 24 hours or more. After this test, examine its appearance and functions.

5-3 High-temperature/high-humidity test

Subject the object to the environmental conditions of $+85^{\circ}\text{C}$ and 90-95% r.h. for 96 hours, then expose to normal temperature/humidity for 24 hours or more. After this test, examine its appearance and functions.

5-4 Thermal shock test

Subject the object to cyclic temperature change (-30°C , 30 minutes \leftrightarrow $+85^{\circ}\text{C}$, 30 minutes) for 5 cycles, the expose to normal temperature/humidity for 24 hours or more.

5-5 Vibration test

5-5-1 Sinusoidal vibration test

Subject the object to vibrations of 5 to 200 to 5Hz swept in 10 minutes, 4.5G at maximum (2mm amplitude), in X and Y directions for two hours each and in Z direction for four hours. After this test, examine its appearance functions.

5-5-2 Vibration test in packaged condition

Subject the object, which is packaged as illustrated, to vibrations of 15 to 60 to 15Hz swept in 6 minutes, 4G at maximum (2mm amplitude at maximum), applied in X, Y and Z directions for two hours each, i.e. six hours in total. After this test, examine its appearance and functions.

5-6 Free fall test in packaged condition

Drop the object, which is packaged as illustrated, to a concrete surface from the height of 90 cm, on one comer, three edges and six faces once each, i.e. 10 times in total. After this, check the appearance and functions.

5-7 Soldering Heat Resistance Test:

After the lead pins of the unit are soaked in solder bath at $270 \pm 5^{\circ}\text{C}$ for 10 ± 0.5 seconds and then be left for more than 1 hour at $25 \pm 5^{\circ}\text{C}$ in less than 65% relative humidity.

5-8 Adhesion Test:

The device is subjected to be soldered on test PCB. Then apply 0.5Kg (5N) of force for 10 ± 1 seconds in the direction of parallel to the substrate. (the soldering should be done by reflow and be conducted with care so that the soldering is uniform and free of defect by stress such as heat shock) .

6 Inspection

As for the examination in the mass production, the receiving character of the ratio wave sent in a shield box from the standard antenna and VSWR are confirmed in the picking out examination.

7 Warranty

If any defect occurs from the product during proper use within a year after delivery, it will be repaired or replaced free of charge.

8 Other

Any question arising from this specification manual shall be solved by arrangement made by both parties.

9 Precautions for use

- Antenna pattern use a Ag electrode.
- Please don't use the corrosion gas (sulfur gas, chlorine gas) in the atmosphere.
- Please don't direct solder onto the gold electrode of Antenna pattern.

10 Drawings

Shape and Dimension

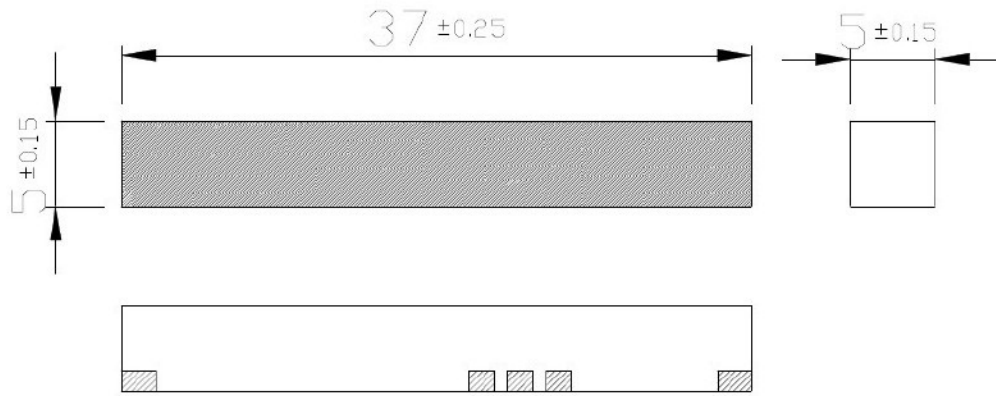

Unit:mm

Customer's Requirement Layout Dimension

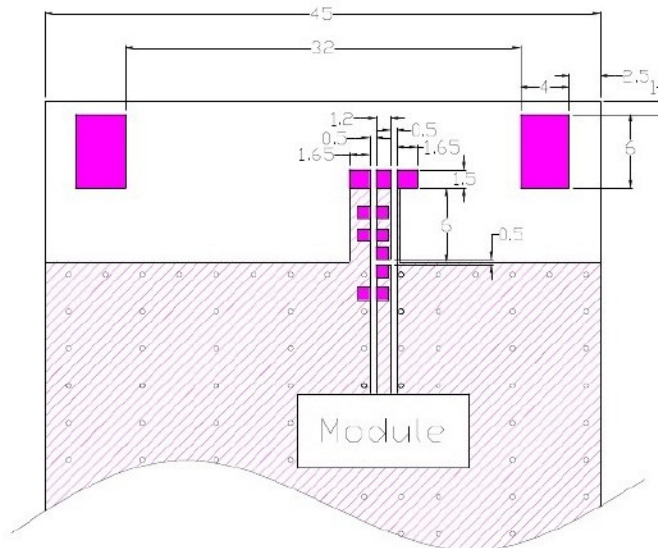

■ Matching circuit

Recommend foot print for Evaluation Board

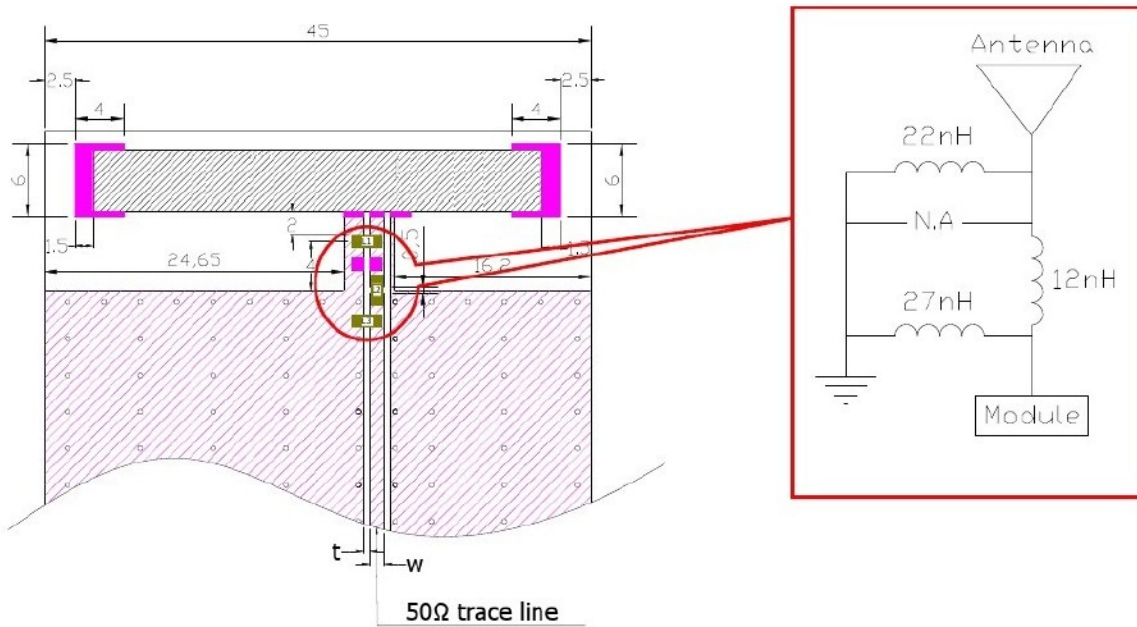

t, w = Unique dimensioning according to your PCB.

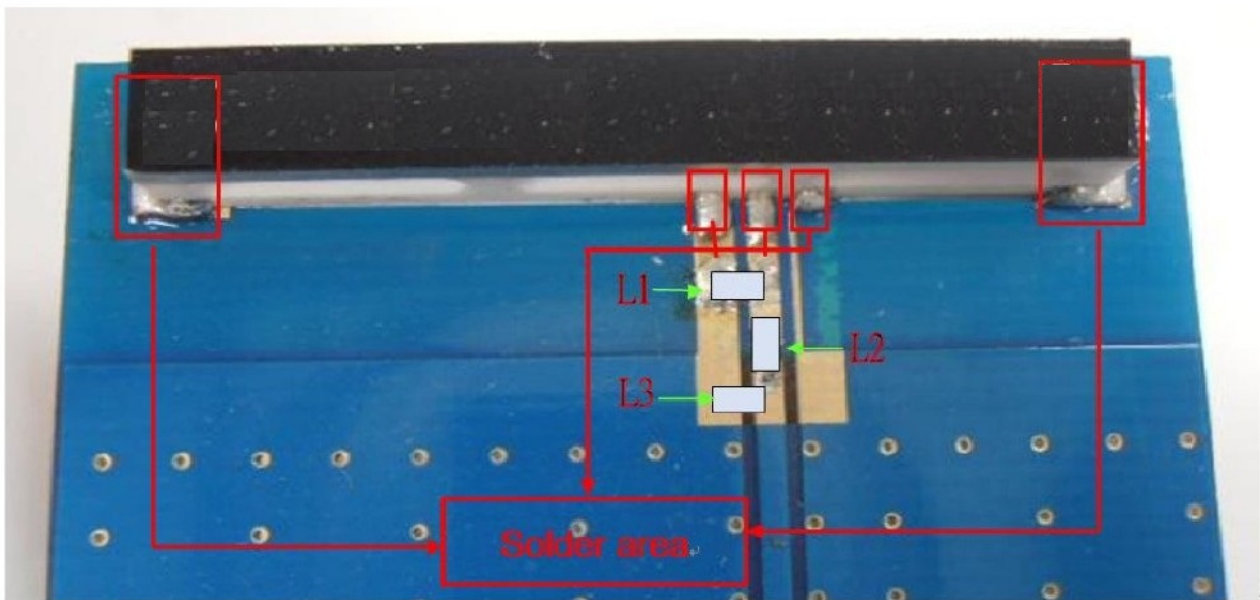

Circuit Symbol	Size	Description
L1	0402	22nH Inductor (MLK1005S22NJ)
L2	0402	12nH Inductor (MLK1005S12NJ)
L3	0402	27nH Inductor (MLK1005S27NJ)

Test board dimensions

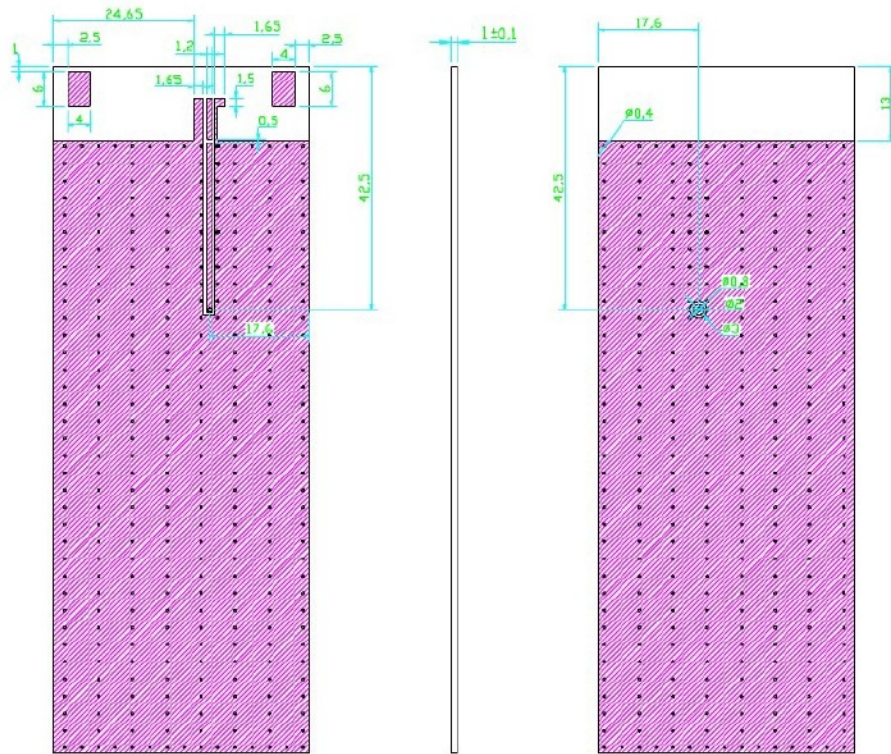

The test board is designed for evaluation purposes

Delivery mode

- 1 Blister tape to IEC 286-3 , polyester •
- 2 Pieces/tape : 450 pcs

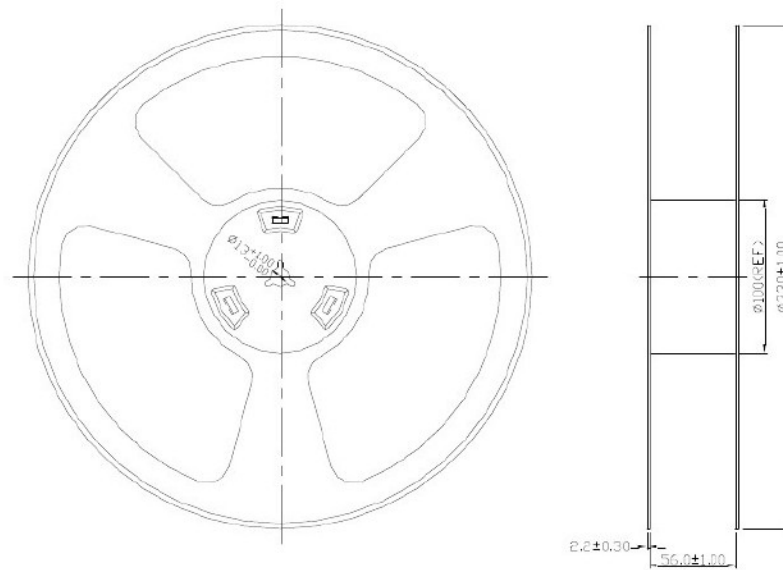

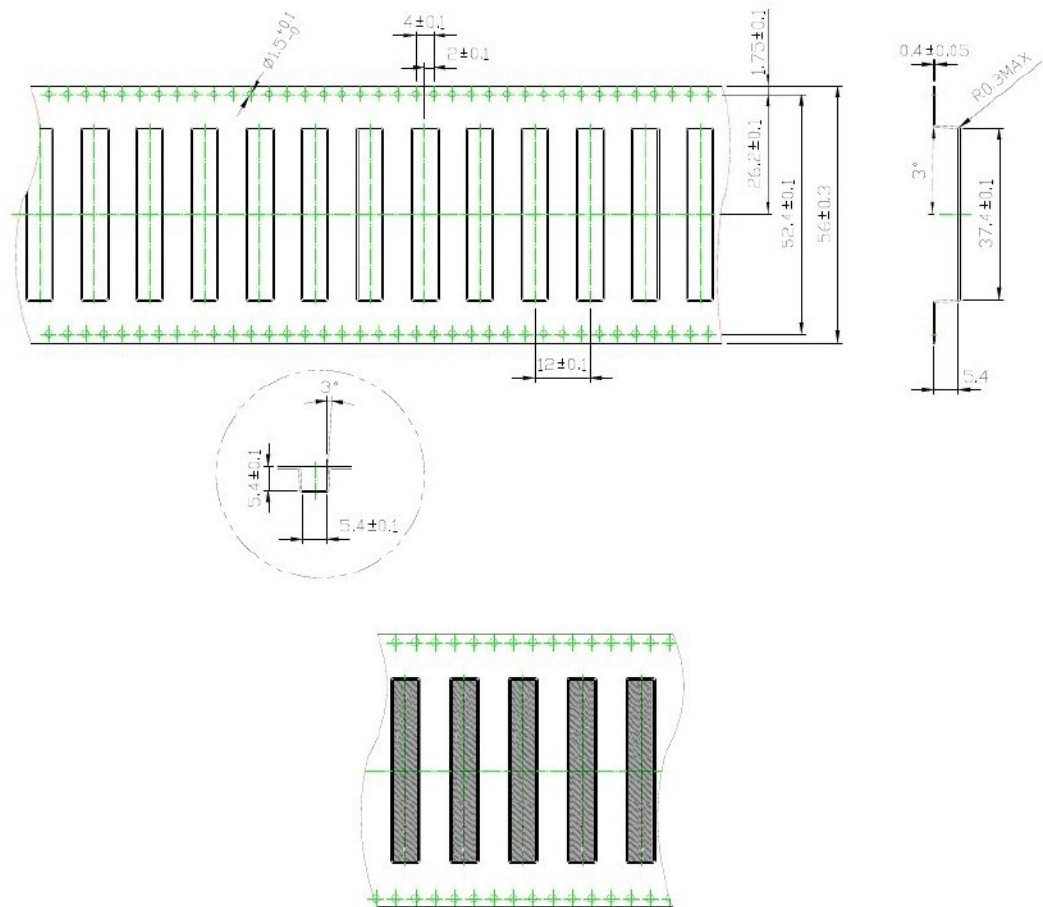

Transmission line and matching

Typical config.1

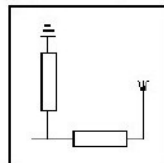

Typical config.2

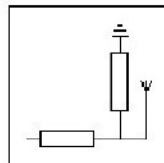

Component types

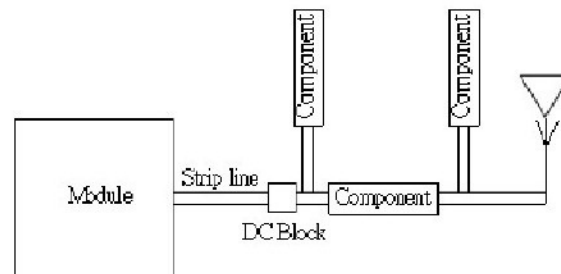
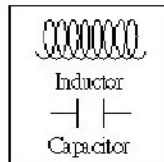

The matching network has to be individually designed using one,two or three components.

11 Recommended Reflow Soldering Profile

Chinmore products can be assembled following Pb-free assembly. According to the Standard IPC/JEDEC J-STD-020C, the temperature profile suggested is as follow.

Phase	Profile features	Pb-Free Assembly (SnAgCu)
PREHEAT	-Temperature Min(T_{smin}) -Temperature Max(T_{smax}) -Time(t_s) form (T_{smin} to T_{smax})	150°C 200°C 60-120 seconds
RAMP-UP	Avg. Ramp-up Rate (T_{smax} to TP)	3°C/second(max)
REFLOW	-Temperature(T_L) -Total Time above T_L (t_L)	217°C 30-100 seconds
PEAK	-Temperature(T_P) -Time(t_p)	260°C 20-30 second
RAMP-DOWN	Rate	6°C / second max.
Time from 25°C to Peak Temperature		8 minutes max.
Composition of solder paste		96.5Sn/3Ag/0.5Cu
Solder Paste Model		SHENMAO PF606-P26

Note : All the temperature measure point is on top surface of the component, if temperature over recommend, it will make component surface peeling or damage.

The graphic shows temperature profile for component assembly process in reflow ovens

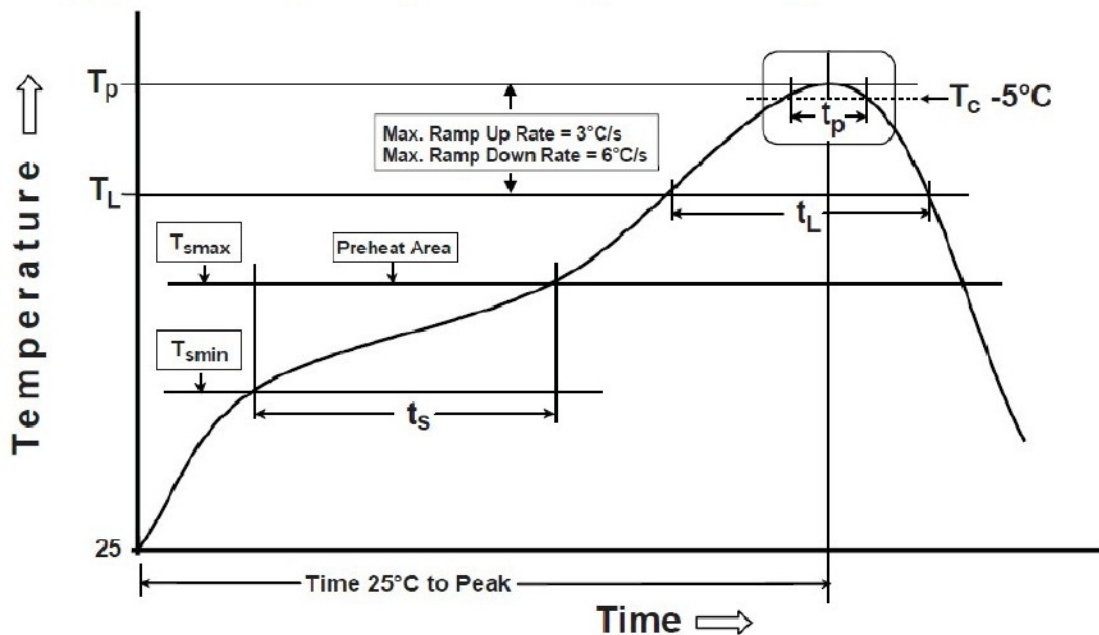

Soldering With Iron:

Soldering condition : Soldering iron temperature 270 ± 10 °C.

Apply preheating at 120°C for 2-3 minutes. Finish soldering for each terminal within 3 seconds, if soldering iron over temperature 270 ± 10 °C or 3 seconds, it will make component surface peeling or damage. Soldering iron can not leakage of electricity.