

Chinmore Industry Co.,Ltd.

PART NUMBER: GA-076

1. SCOPE

This specification covers the print chip antenna for ISM Band.

2. Name of the product

This product is named "Print Chip Antenna".

3. Electrical characteristics

3-1 Electrical characteristics of antenna

The antenna has the electrical characteristics given in Table 1 under the Chinmore standard installation conditions shown in the figure of Evaluation Board.

Table 1

No	Parameter	Specification
1	Working Frequency	868 / 915 MHz
2	Dimension	15x4.0x1.2 mm
3	Polarization	Linear
4	Azimuth	Omni-directional
5	Impedance	50 Ω
6	Operating Temperature	-40~85°C

* Actual value will depend on customer ground plane size

3-2 S11 & Efficiency Measurement ANT 1.

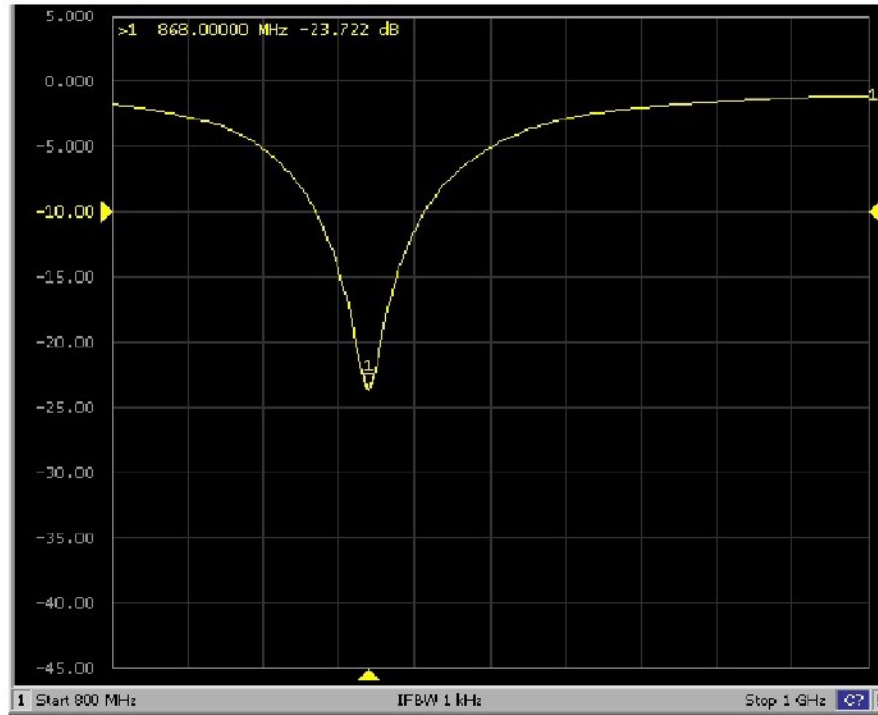

Return Loss : -23.72dB @868MHz

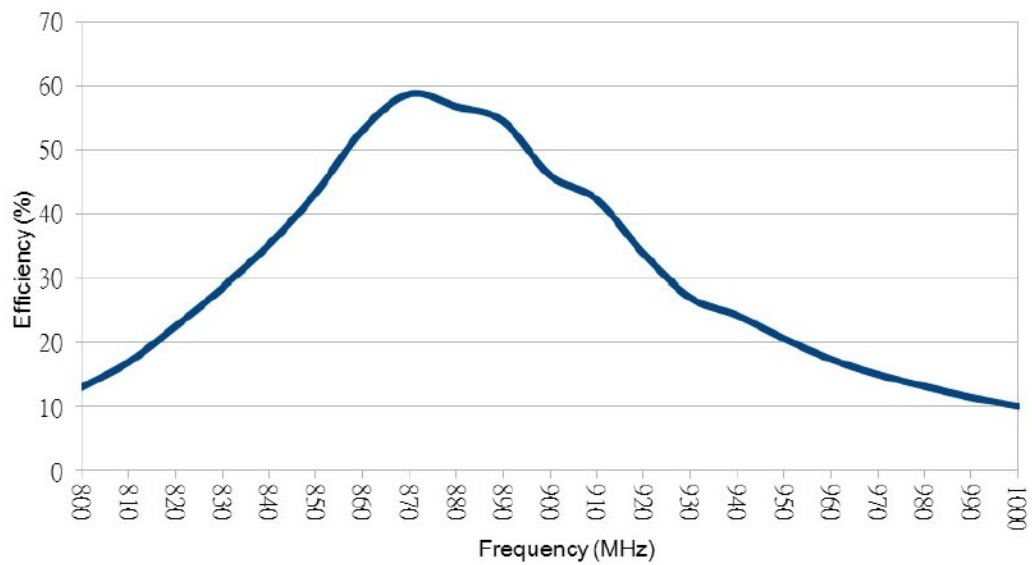

Efficiency(%) : 58.81@868MHz

XZ-Plane 868MHz

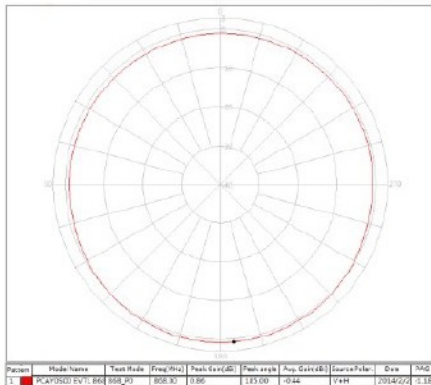

YZ-Plane 868MHz

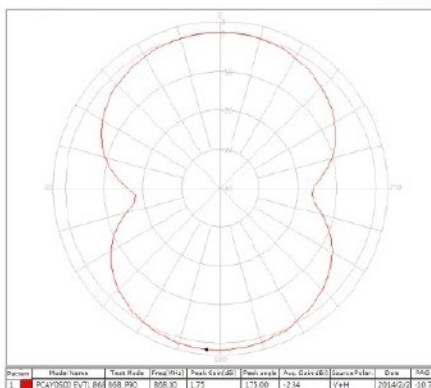

XY-Plane 868MHz

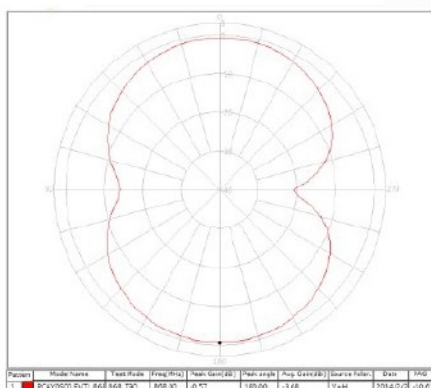

868MHz	Peak Gain (dBi)
XZ-Plane	0.86
YZ-Plane	1.75
XY-Plane	-0.57

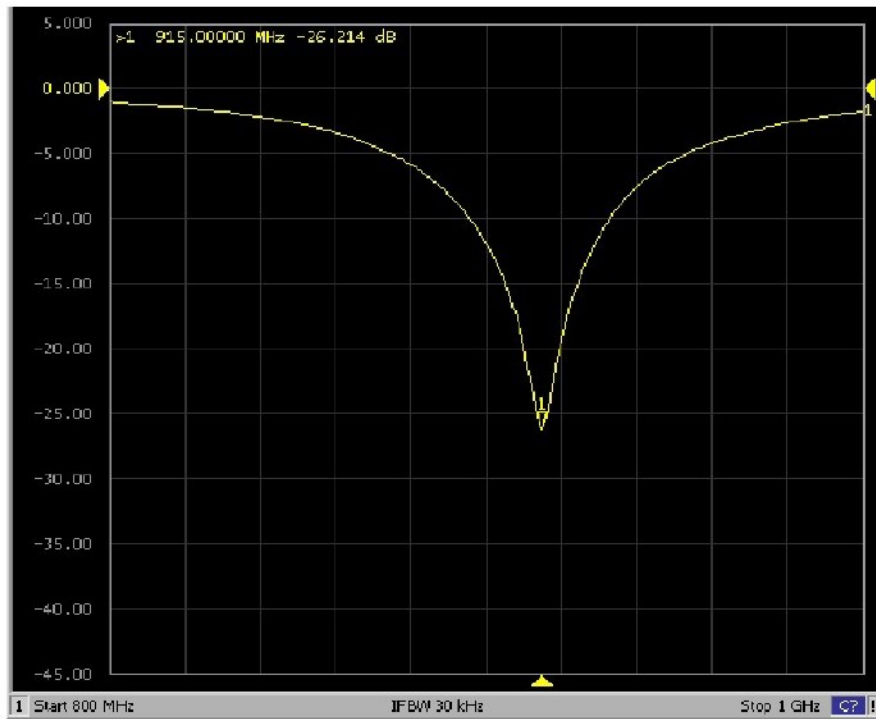

Return Loss : -26.21dB @915MHz

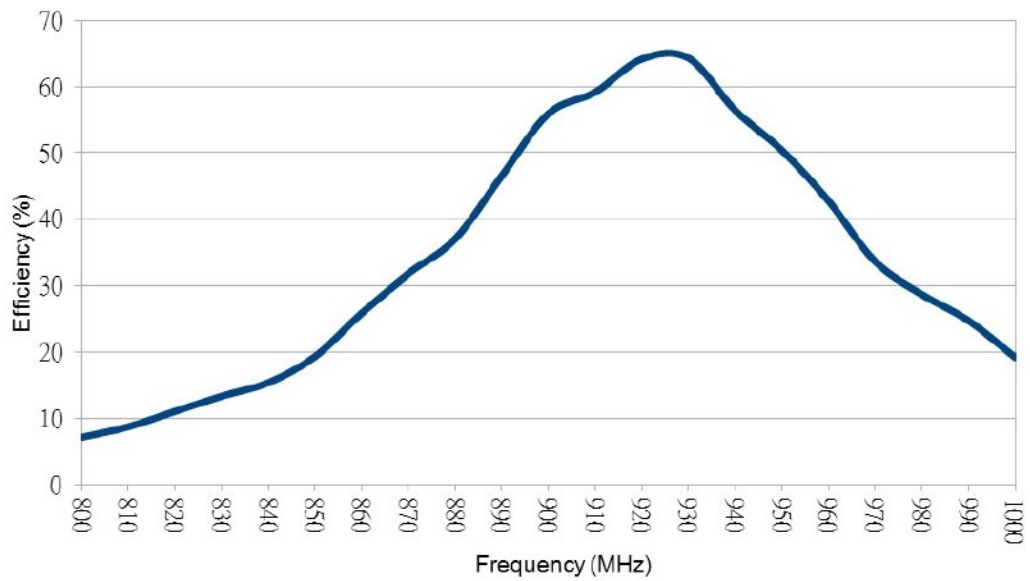

Efficiency(%) : 59.13 @915MHz

XZ-Plane 915MHz

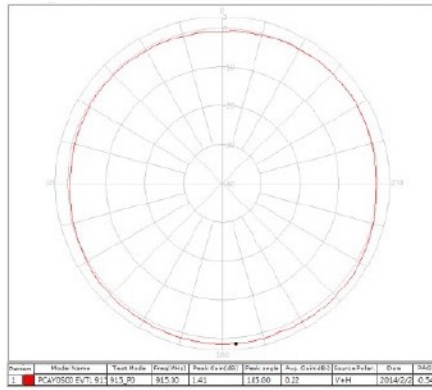

YZ-Plane 915MHz

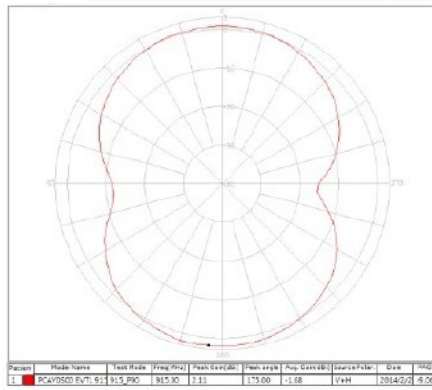

XY-Plane 915MHz

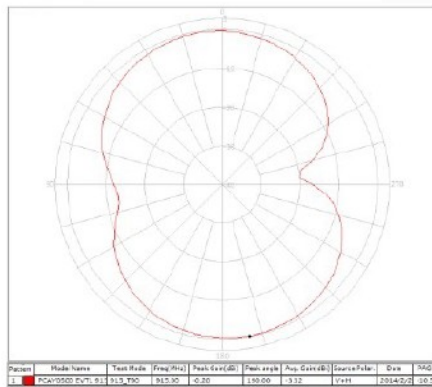

915MHz	Peak Gain (dBi)
XZ-Plane	1.41
YZ-Plane	2.11
XY-Plane	-0.20

ANT 2.

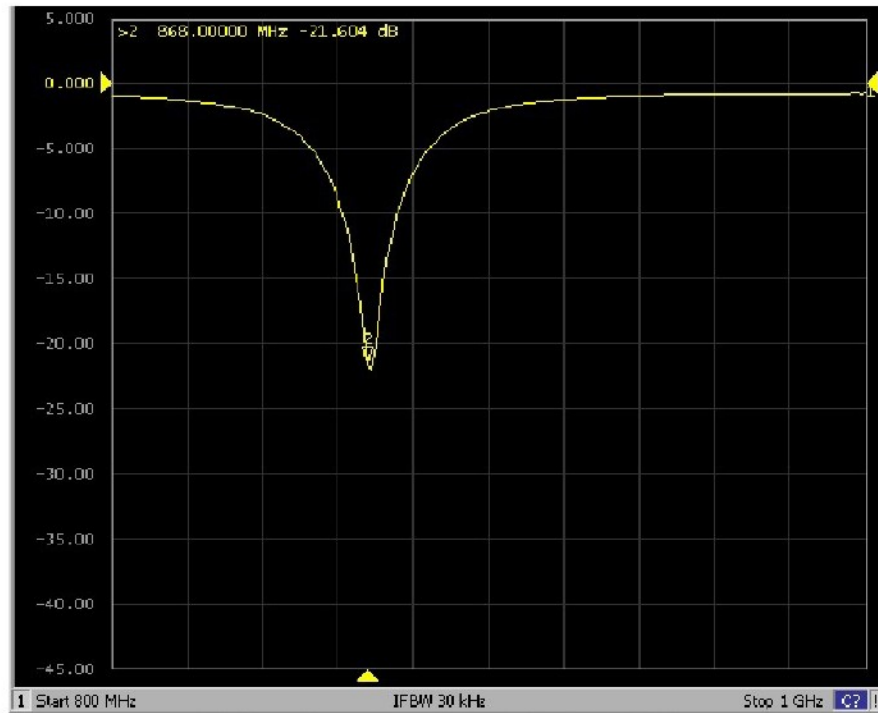

Return Loss : -21.60dB @868MHz

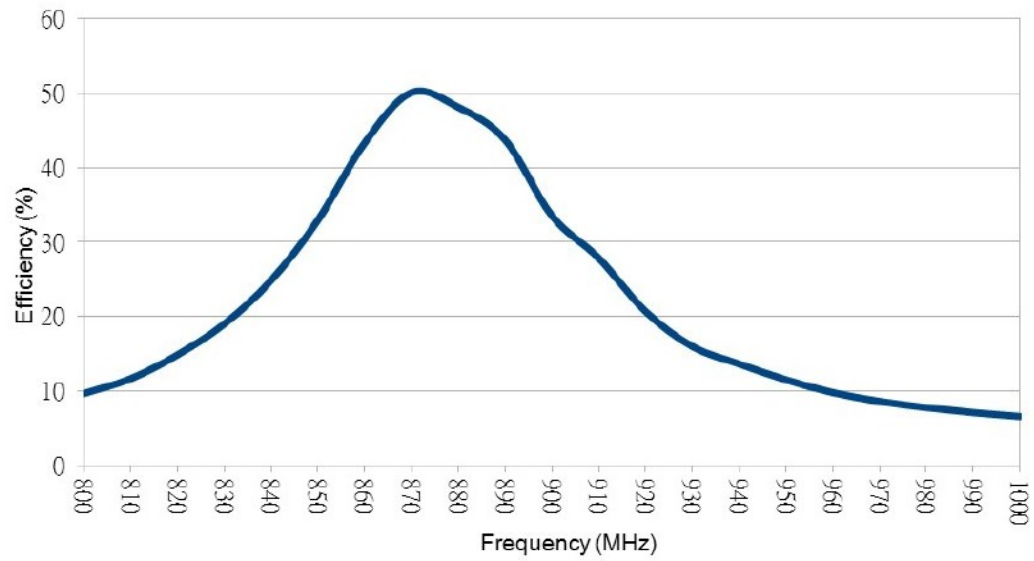

Efficiency(%) : 50.12@868MHz

XZ-Plane 868MHz

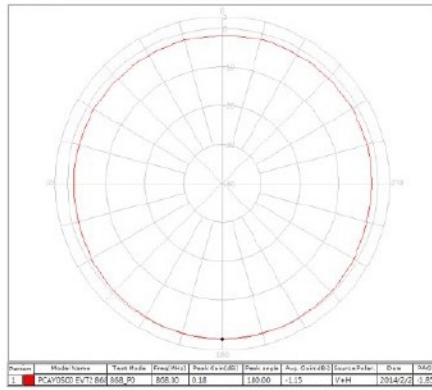

YZ-Plane 868MHz

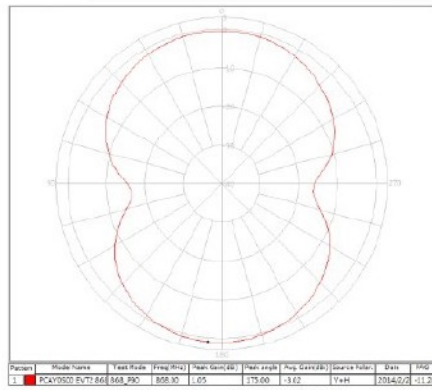

XY-Plane 868MHz

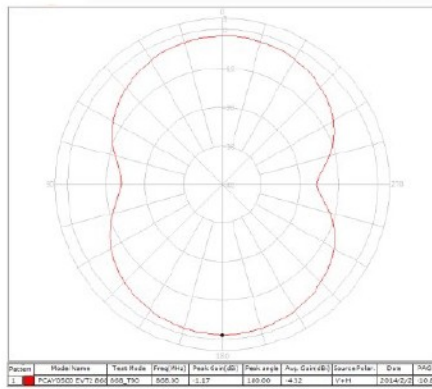

868MHz	Peak Gain (dBi)
XZ-Plane	0.18
YZ-Plane	1.05
XY-Plane	-1.17

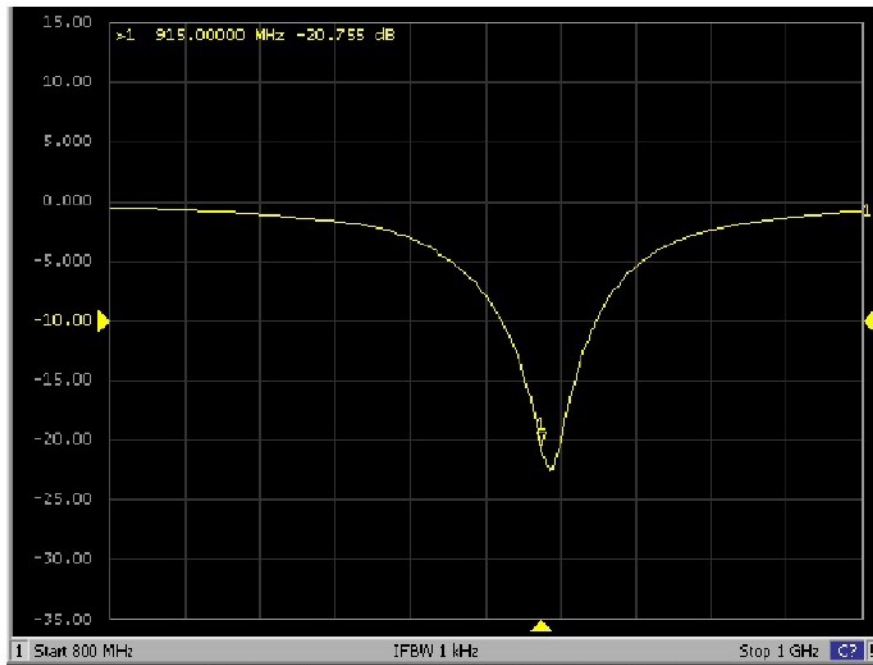

Return Loss : -20.75dB @915MHz

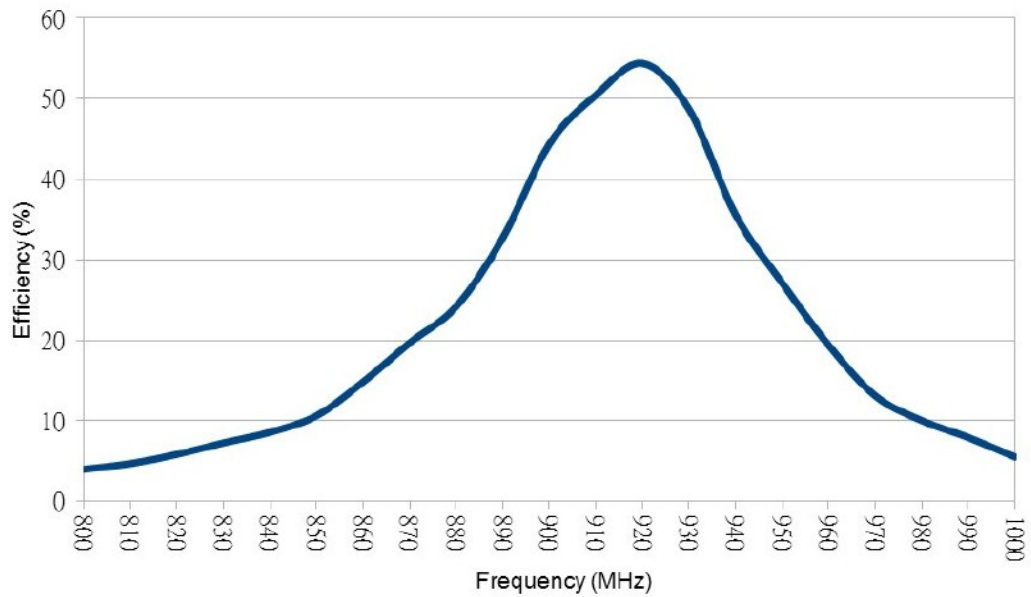

Efficiency(%) : 50.46 @915MHz

XZ-Plane 915MHz

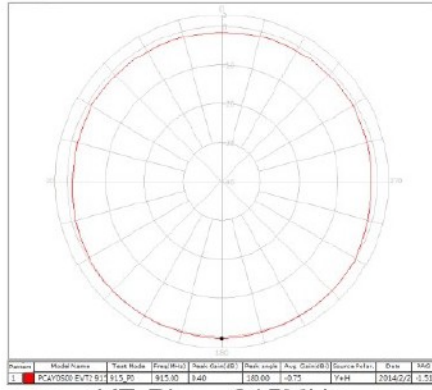

YZ-Plane 915MHz

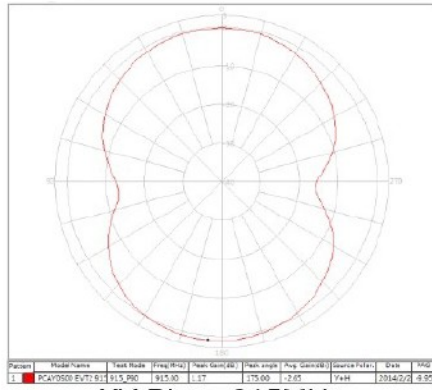

XY-Plane 915MHz

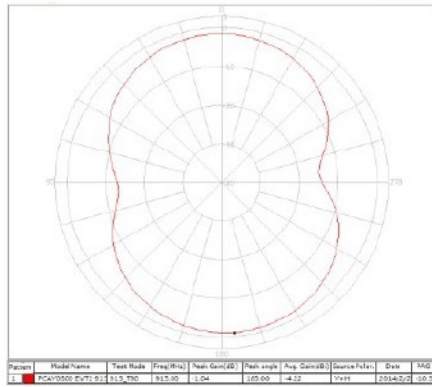

915MHz	Peak Gain (dBi)
XZ-Plane	0.40
YZ-Plane	1.17
XY-Plane	-1.04

4. Antenna & Demo Board Dimension

4-1 Antenna Dimension



Unit : mm

4-2 Demo Board Dimension

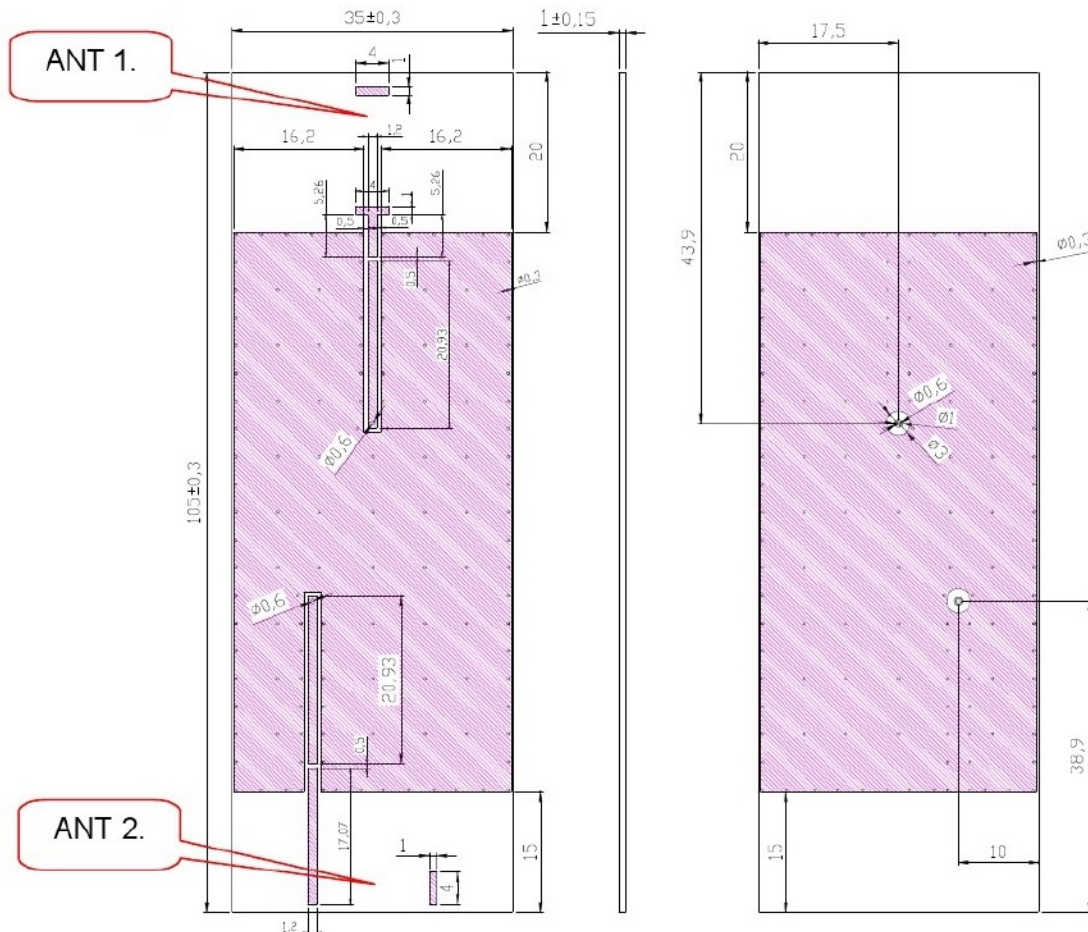

5. Antenna Measurement on Demo Board

5-1 Layout 1 Measurement

5-1-1 Matching Circuit

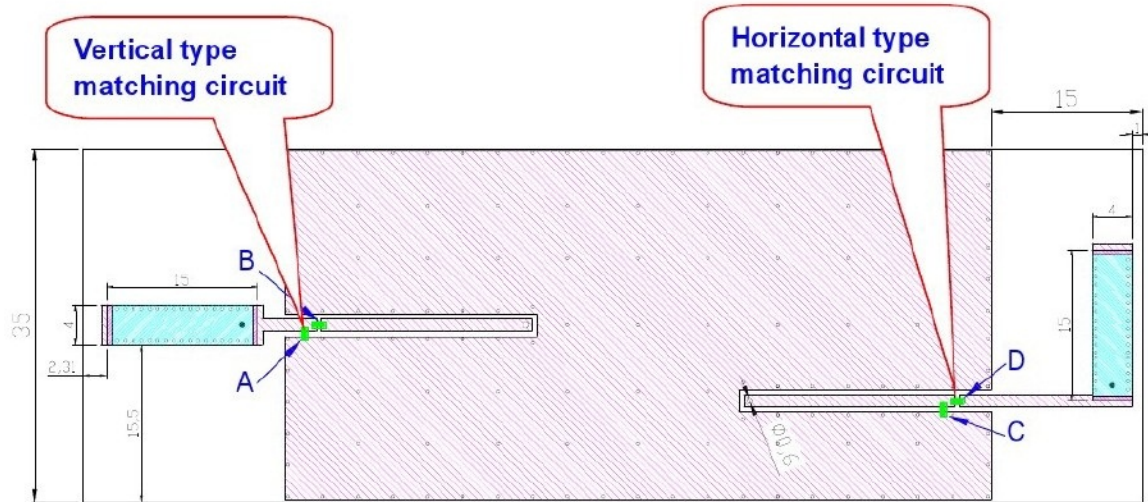

Match Table

Frequency	868 MHz		916 MHz	
Vertical type	A=12nH	B=33nH	A=0.5PF	B=5.6PF
Horizontal type	C=6.8nH	D=4.7PF	D=1.5P	

6. Environmental conditions

6-1 Operating conditions

The antenna has the electrical characteristics given in Tables 1 in the temperature range of -20°C to +80°C and under the environmental conditions of +40°C and 20~80% relative humidity.

6-2 Storage temperature range

The storage temperature range of product is 0°C to +40°C.

7. Reliability tests

7-1 Low-temperature test

Expose the specimen to -40°C for 16 hours and then to normal temperature/humidity for 24 hours or more. After this test, examine its appearance and functions.

7-2 High-temperature test

Expose the specimen to +85°C for 16 hours and then to normal temperature/humidity for 24 hours or more. After this test, examine its appearance and functions.

7-3 High-temperature/high-humidity test

Subject the object to the environmental conditions of +85°C and 90-95% relative humidity for 96 hours, then expose it to normal temperature/humidity for 24 hours or more. After this test, examine its appearance and functions.

7-4 Thermal shock test

Subject the object to cyclic temperature change (-40°C, 30 minutes ⇄ +85°C, 30 minutes) for 5 cycles, then expose it to normal temperature/humidity for 24 hours or more.

7-5 Vibration test

7-5-1 Sinusoidal vibration test

Subject the object to vibrations of 5 to 200 to 5Hz swept in 10 minutes, 4.5G at maximum (2mm amplitude), in X and Y directions for two hours each and in Z direction for four hours. After this test, examine its appearance functions.

7-5-2 Vibration test in packaged condition

Subject the object, which is packaged as illustrated, to vibrations of 15 to 60 to 15Hz swept in 6 minutes, 4G at maximum (2mm amplitude at maximum), applied in X, Y and Z directions for two hours each, i.e. six hours in total. After this test, examine its appearance and functions.

7-6 Free fall test in packaged condition

Drop the object, which is packaged as illustrated, to a concrete surface from the height of 90 cm, on one corner, three edges and six faces once each, i.e. 10 times in total. After this test, examine its appearance and functions.

7-7 Soldering heat resistance test

After the lead pins of the unit are soaked in solder bath at $270 \pm 5^\circ\text{C}$ for 10 ± 0.5 seconds and then be left for more than 1 hour at $25 \pm 5^\circ\text{C}$ in less than 65% relative humidity.

7-8 Adhesion test

The device is subjected to be soldered on test PCB. Then apply 0.5Kg (5N) of force for 10 ± 1 seconds in the direction of parallel to the substrate. (the soldering should be done by reflow and be conducted with care so that the soldering is uniform and free of defect by stress such as heat shock) .

8. Warranty

If any defect occurs from the product during proper use within a year after delivery, it will be repaired or replaced free of charge.

9. Other

Any question arising from this specification manual shall be solved by arrangement made by both parties.

10. Precautions for use

Antenna pattern use a Sn electrode.

Please don't use the corrosion gas (sulfur gas, chlorine gas) in the atmosphere.

Please don't direct solder onto the Sn electrode of Antenna pattern.

11. Delivery mode

1. Blister tape to IEC 286-3 , polyester .
- 2 .Pieces/tape : 5000pcs.

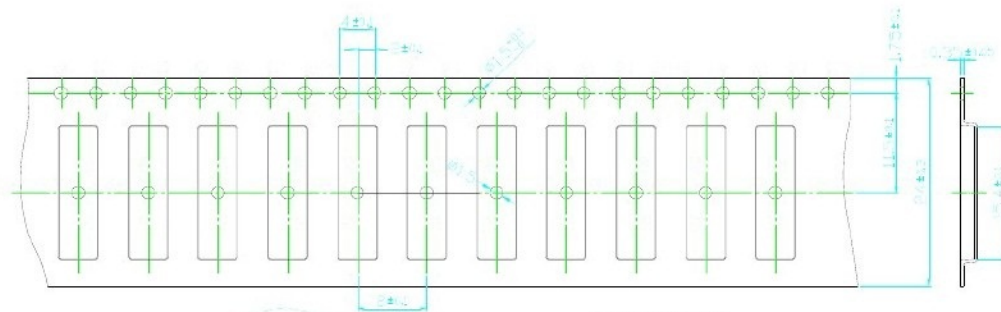
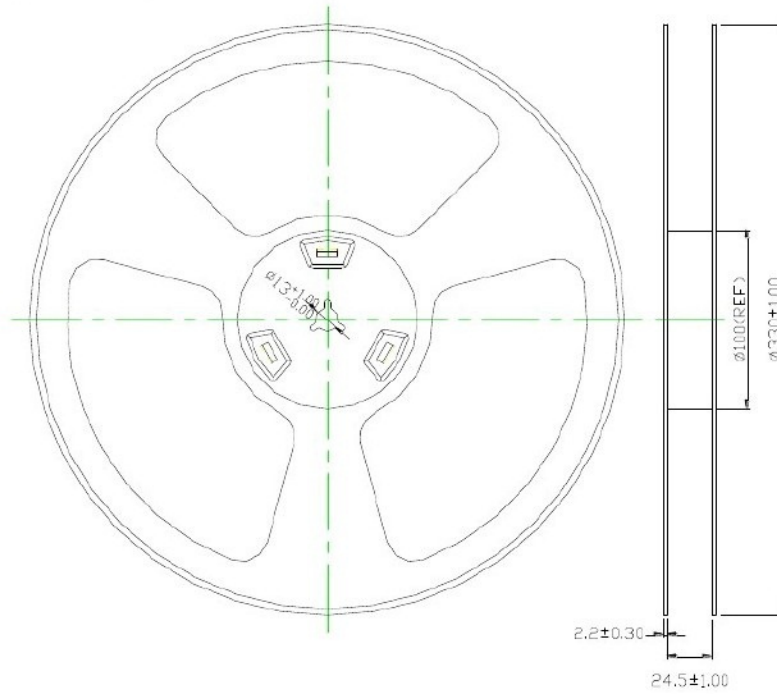

註:1.材質為透明

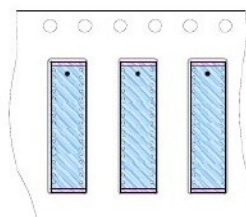
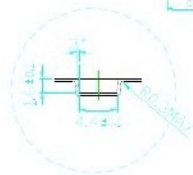

12. Recommended Reflow Temperature Profile

Chinmore products can be assembled following Pb-free assembly. According to the Standard IPC/JEDEC J-STD-020C, the temperature profile suggested is as follow.

Phase	Profile features	Pb-Free Assembly (SnAgCu)
PREHEAT	-Temperature Min(T_{smin}) -Temperature Max(T_{smax}) -Time(t_s) form (T_{smin} to T_{smax})	150°C 200°C 60-120 seconds
RAMP-UP	Avg. Ramp-up Rate (T_{smax} to TP)	3°C/second(max)
REFLOW	-Temperature(T_L) -Total Time above T_L (t_L)	217°C 30-100 seconds
PEAK	-Temperature(T_P) -Time(t_p)	260°C 5 second
RAMP-DOWN	Rate	6°C / second max.
Time from 25°C to Peak Temperature		8 minutes max.
Composition of solder paste		96.5Sn/3Ag/0.5Cu
Solder Paste Model		SHENMAO PF606-P26

Note : All the temperature measure point is on top surface of the component, if temperature over recommend, it will make component surface peeling or damage.

The graphic shows temperature profile for component assembly process in reflow ovens

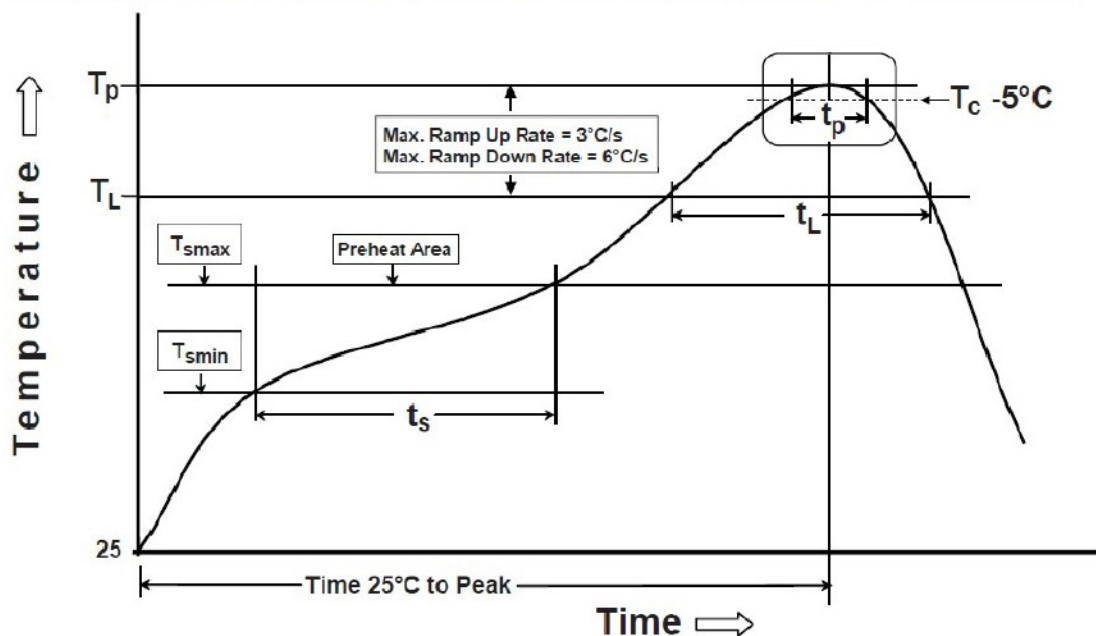

Soldering With Iron:

Soldering condition : Soldering iron temperature 270 ± 10 °C.

Apply preheating at 120°C for 2-3 minutes. Finish soldering for each terminal within 3 seconds, if soldering iron over temperature $270\pm 10^{\circ}\text{C}$ or 3 seconds, it will make component surface peeling or damage. Soldering iron can not leakage of electricity.