

CHINMORE INDUSTRY CO.,LTD.

PART NUMBER: GA-035

1 SCOPE

This specification covers the dielectric antenna for **824~960MHz, 1710~2170 MHz** application.

2 Name of the product

This product is named "Dielectric Antenna".

3 Electrical characteristics

3-1 Electrical characteristics of antenna

The antenna has the electrical characteristics given in Table 1 under the chinmore standard installation conditions shown in the figure of Evaluation Board.

Table 1

| No | Parameter | Specification |
|----|-----------------------|--|
| 1 | Working Frequency | 824~960 MHz , 1710~2170 MHz |
| 2 | Dimension | 35×6×5 mm |
| 3 | VSWR | 3.5 max (depends on the special environment) |
| 4 | Polarization | Linear |
| 5 | Impedance | 50 Ω |
| 6 | Operating Temperature | -40~85°C |
| 7 | Termination | Ag (Environmentally-Friendly Pb Free) |

* Evaluation board size 40X110 mm²

* Actual Electrical value will depend on customer ground plane size

S11 Response curve

▶ S11 Log Mag 3.000dB/ Ref 0.000dB [F1]

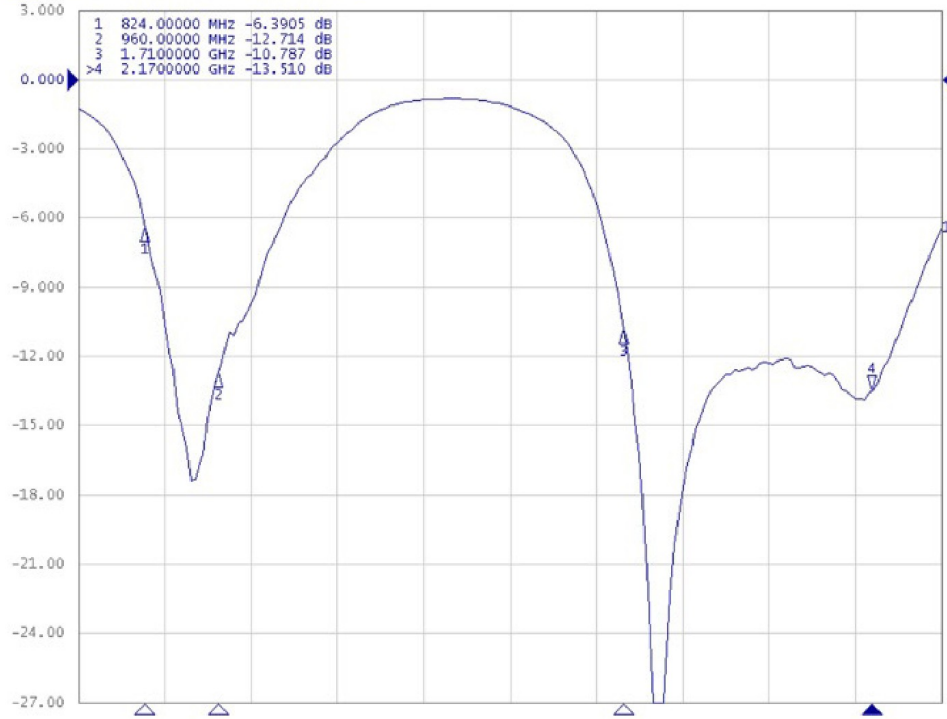

▶ S11 Smith (R+jX) scale 1.000U [F1]

| Marker | Frequency | Real (Ω) | Imag (Ω) | Component |
|--------|---------------|----------|----------|-----------|
| 1 | 824.00000 MHz | 32.824 | -41.861 | 4.6141 pF |
| 2 | 960.00000 MHz | 51.214 | 29.208 | 4.8422 nH |
| 3 | 1.7100000 GHz | 31.210 | 8.0208 | 746.52 pH |
| 4 | 2.1700000 GHz | 36.866 | -11.950 | 6.1373 pF |

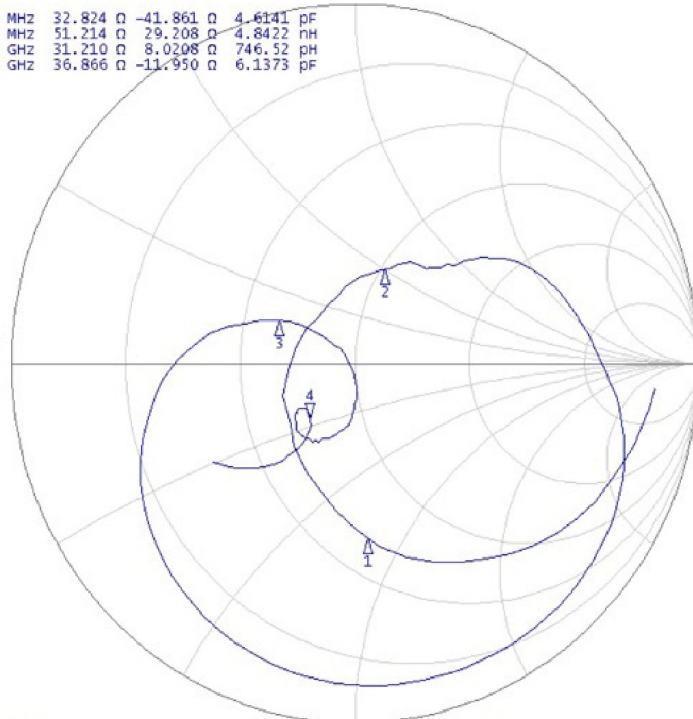

Gain and Efficiency

(Ground length: 9.5cm)

| Penta-Band antenna peak gain parameter summary | | | | | | | | | | |
|--|-----------|------|------|------|-----------|------|-----------|------|-------------|------|
| Band | GSM (MHz) | | | | DCS (MHz) | | PCS (MHz) | | WCDMA (MHz) | |
| | 824 | 890 | 880 | 960 | 1710 | 1880 | 1850 | 1990 | 2110 | 2170 |
| Peak Gain(dBi) | 1.49 | 0.92 | 1.76 | 1.35 | 2.53 | 2.38 | 2.30 | 2.46 | 2.69 | 4.62 |
| Efficiency(%) | 60.6 | 65.4 | 69.3 | 64.6 | 54.7 | 63.1 | 61.6 | 51.5 | 56.2 | 65.8 |

Reference efficiency data with different ground plane length :

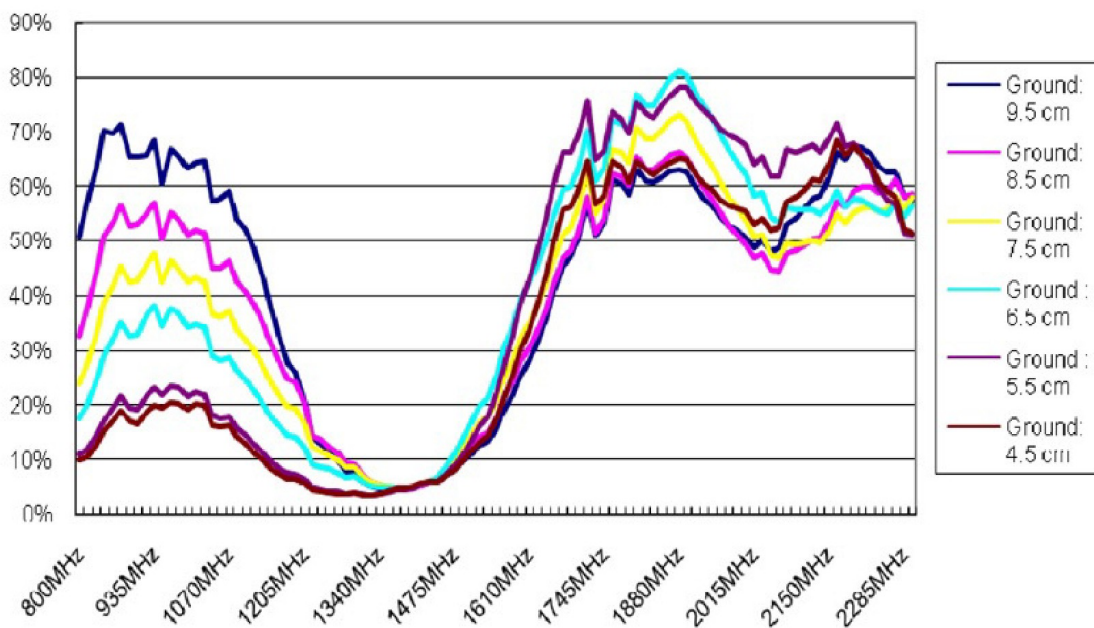

3D Radiation Pattern (measure on CHINMORE EVB)

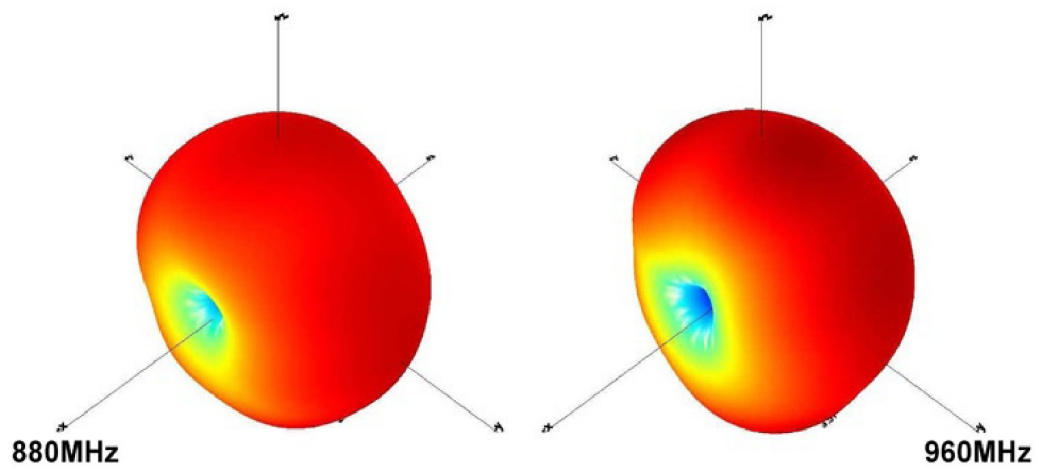
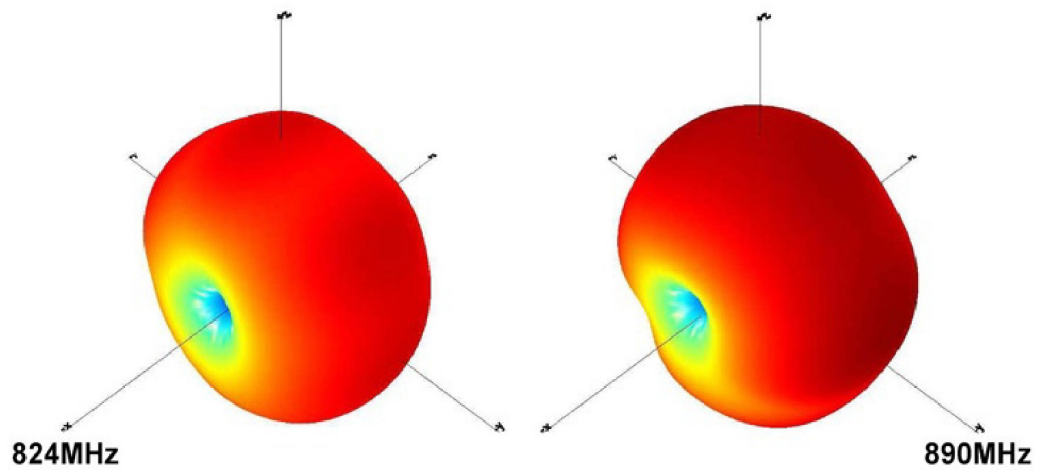
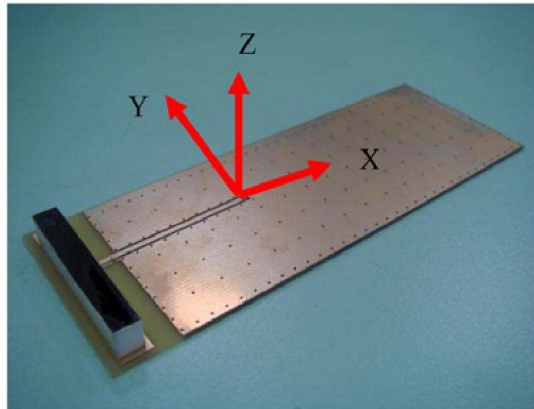

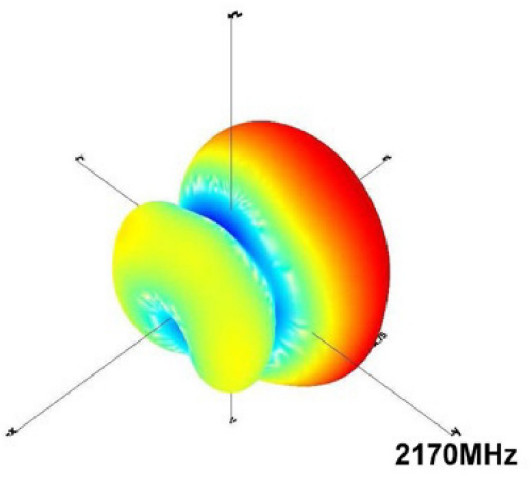
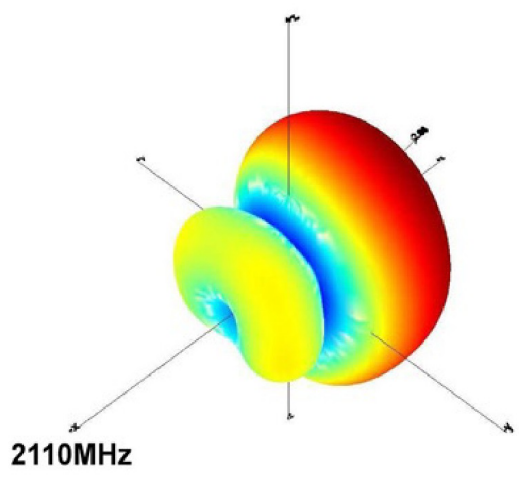
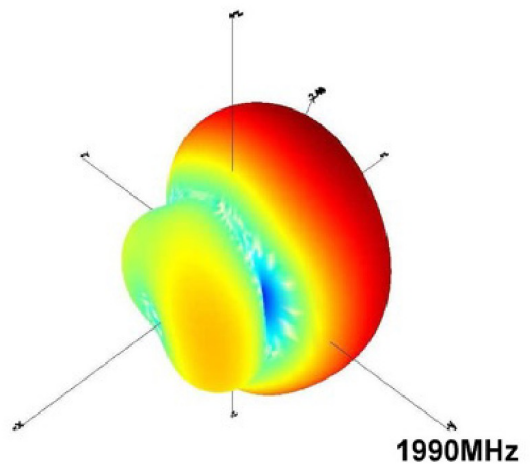
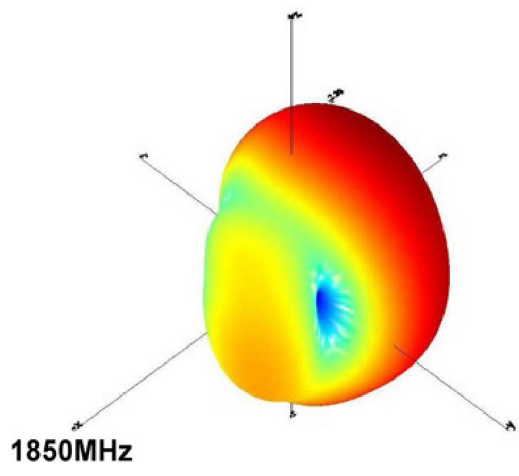
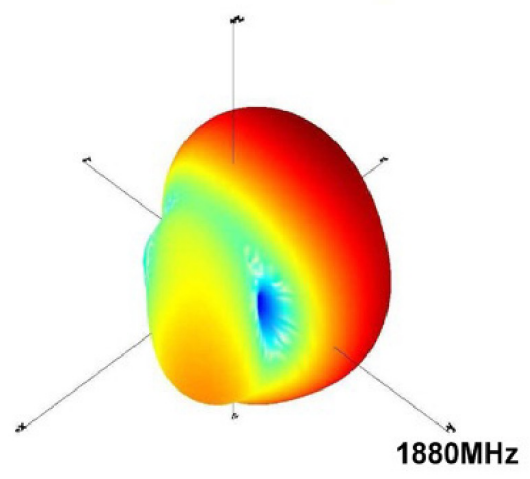
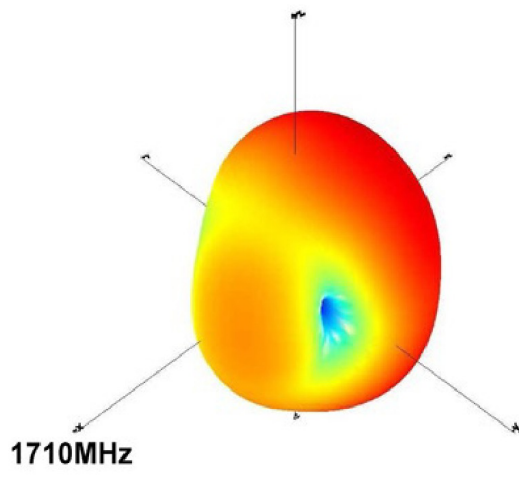

4 Environmental conditions

4-1 Operating conditions

The antenna has the electrical characteristics given in Tables 1 in the temperature range of -30°C to $+85^{\circ}\text{C}$ and under the environmental conditions of $+40^{\circ}\text{C}$ and 0-95 % r.h..

4-2 Storage temperature range

The storage temperature range of product is -40°C to $+85^{\circ}\text{C}$

5 Reliability tests

5-5-2 and 5-6 examination of enforced. Moreover, the decision standard of the movement confirmation is judged by 3 and 4 of the tables-1, and the decision standard of the appearance isn't thought function problem become defect be.

The decision standard of the confirmation of the movement is doing the characteristic electric standard of the antenna module. And, the decision standard of the appearance isn't thought function problem become defect be.

5-1. Low-temperature test

Expose the specimen to -30°C for 500 hours and then to normal temperature/humidity for 24 hours or more. After that examine the appearance and functions.

5-2 High-temperature test

Expose the specimen to $+85^{\circ}\text{C}$ for 500 hours and then to normal temperature/humidity for 24 hours or more. After that examine the appearance and functions.

5-3 High-temperature/high-humidity test

Subject the object to the environmental conditions of $+85^{\circ}\text{C}$ and 90-95% r.h. for 96 hours, then expose to normal temperature/humidity for 24 hours or more After this, check the appearance and functions.

5-4 Thermal shock test

Subject the object to cyclic temperature change (-30°C , 30 minutes \leftrightarrow $+85^{\circ}\text{C}$, 30 minutes) for 5 cycles, the expose to normal temperature/humidity for 24 hours or more.

5-5 Vibration test

5-5-1 Sinusoidal vibration test

Subject the object to vibrations of 5 to 200 to 5Hz swept in 10 minutes, 4.5G at maximum (2mm amplitude), in X and Y directions for two hours each and in Z direction for four hours. After this, check the appearance functions.

5-5-2 Vibration test in packaged condition

Subject the object, which is packaged as illustrated, to vibrations of 15 to 60 to 15Hz swept in 6 minutes, 4G at maximum (2mm amplitude at maximum), applied in X, Y and Z directions for two hours each, i.e. six hours in total. After this, check the appearance and functions.

5-6 Free fall test in packaged condition

Drop the object, which is packaged as illustrated, to a concrete surface from the height of 90 cm, on one corner, three edges and six faces once each, i.e. 10 times in total. After this, check the appearance and functions.

5-7. Soldering Heat Resistance Test:

After the lead pins of the unit are soaked in solder bath at $270 \pm 5^{\circ}\text{C}$ for 10 ± 0.5 seconds and then be left for more than 1 hour at $25 \pm 5^{\circ}\text{C}$ in less than 65% relative humidity.

5-8. Adhesion Test:

The device is subjected to be soldered on test PCB. Then apply 0.5Kg(5N) of force for 10 ± 1 seconds in the direction of parallel to the substrate. (the soldering should be done by reflow and be conducted with care so that the soldering is uniform and free of defect by stress such as heat shock) .

6 Inspection

As for the examination in the mass production, the receiving character of the ratio wave sent in a shield box from the standard antenna and VSWR are confirmed in the picking out examination.

7 Warranty

If any defect occurs from the product during proper use within a year after delivery, it will be repaired or replaced free of charge.

8 Other

Any question arising from this specification manual shall be solved by arrangement made by both parties.

9 Precautions for use

- Antenna pattern use a Ag electrode.
- Please don't use the corrosion gas (sulfur gas, chlorine gas) in the atmosphere.
- Please don't direct solder onto the gold electrode of Antenna pattern.

10 Drawings

Shape and Dimension

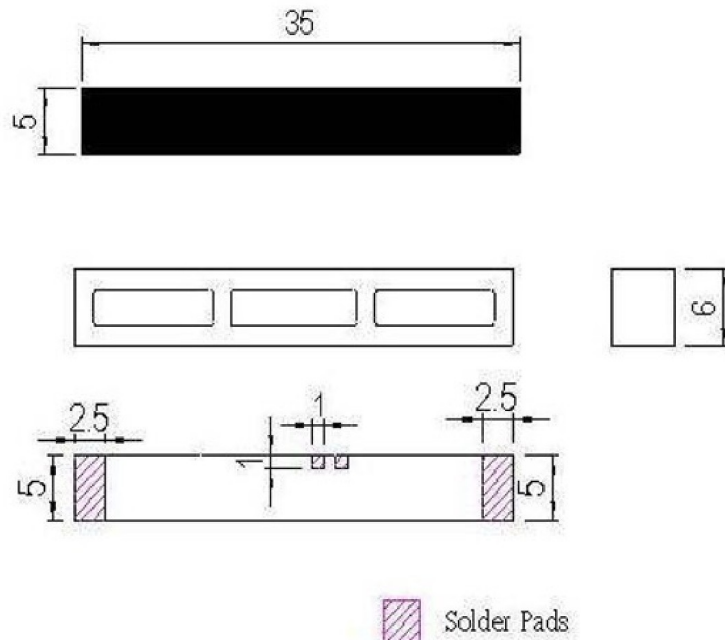

Recommend foot print for Evaluation Board

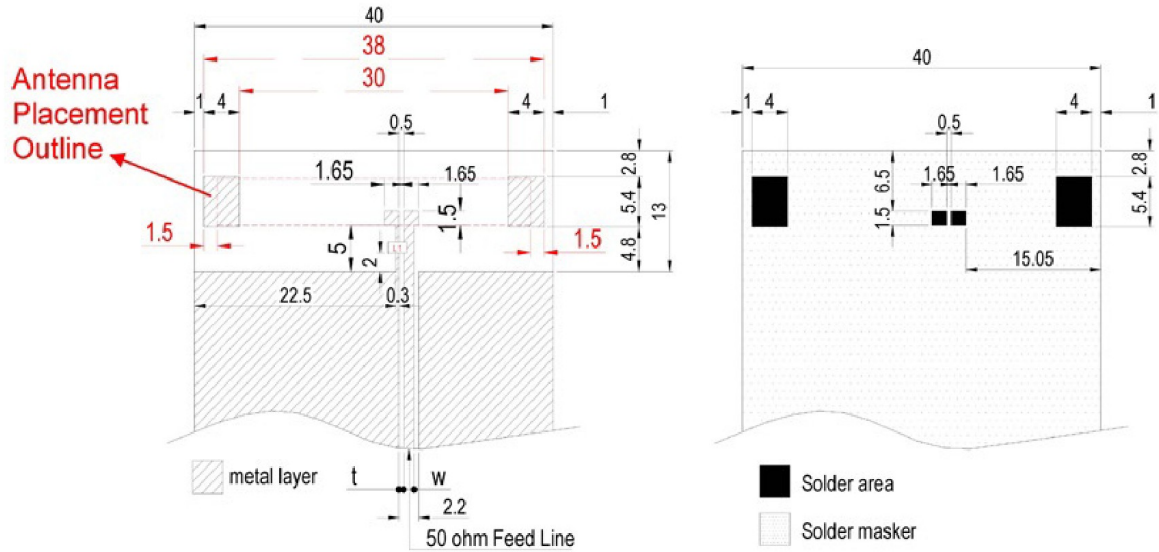

Tolerances unless otherwise specified $\pm 0.1\text{mm}$

t,w=Unique dimensioning according to your PCB.

| Circuit Symbol | Size | Description |
|----------------|------|--------------------------------|
| L1 | 0402 | 6.8nH Inductor (MLK1005S15NIT) |

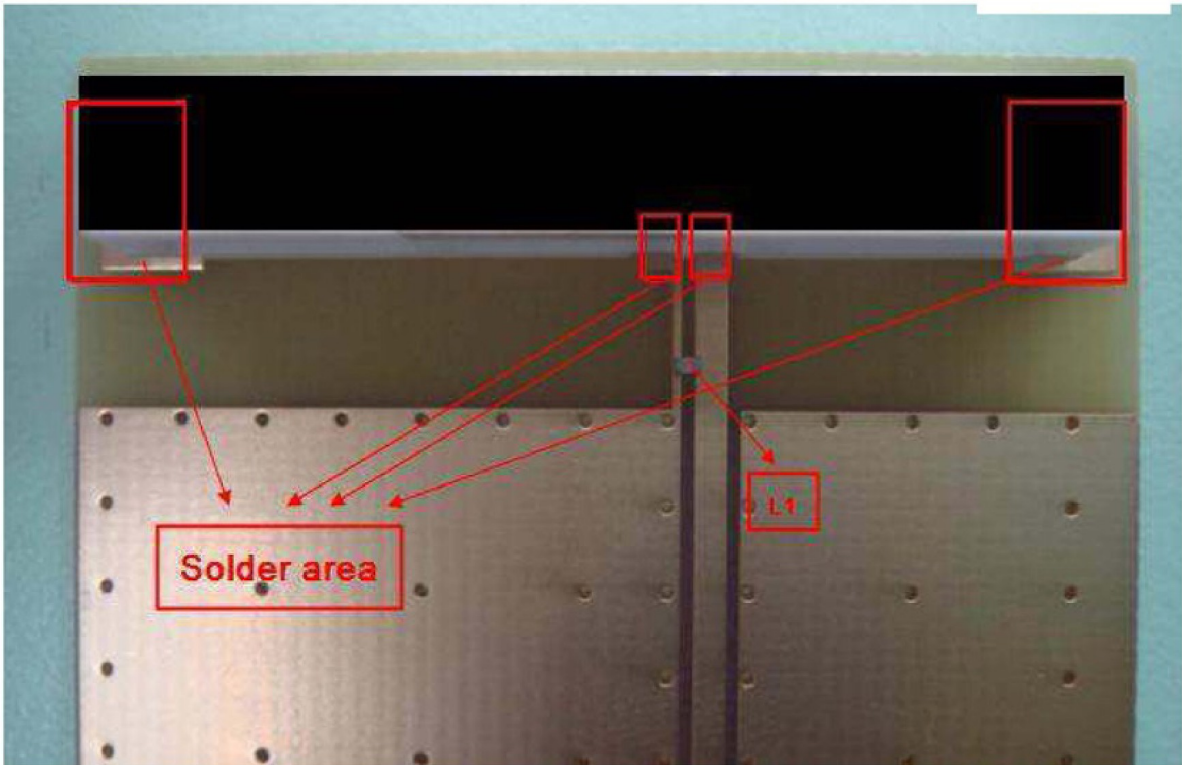

| Circuit Symbol | Size | Description |
|----------------|------|--------------------------------|
| L1 | 0402 | 6.8nH Inductor (MLK1005S15NIT) |

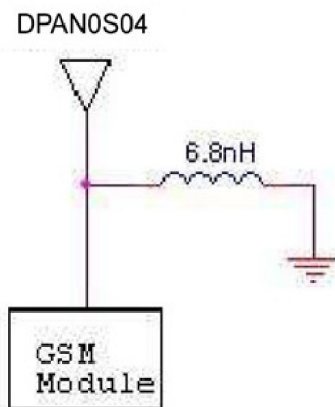

Delivery mode

1 Blister tape to IEC 286-3 , polyester ◦

2 Pieces/tape : 450

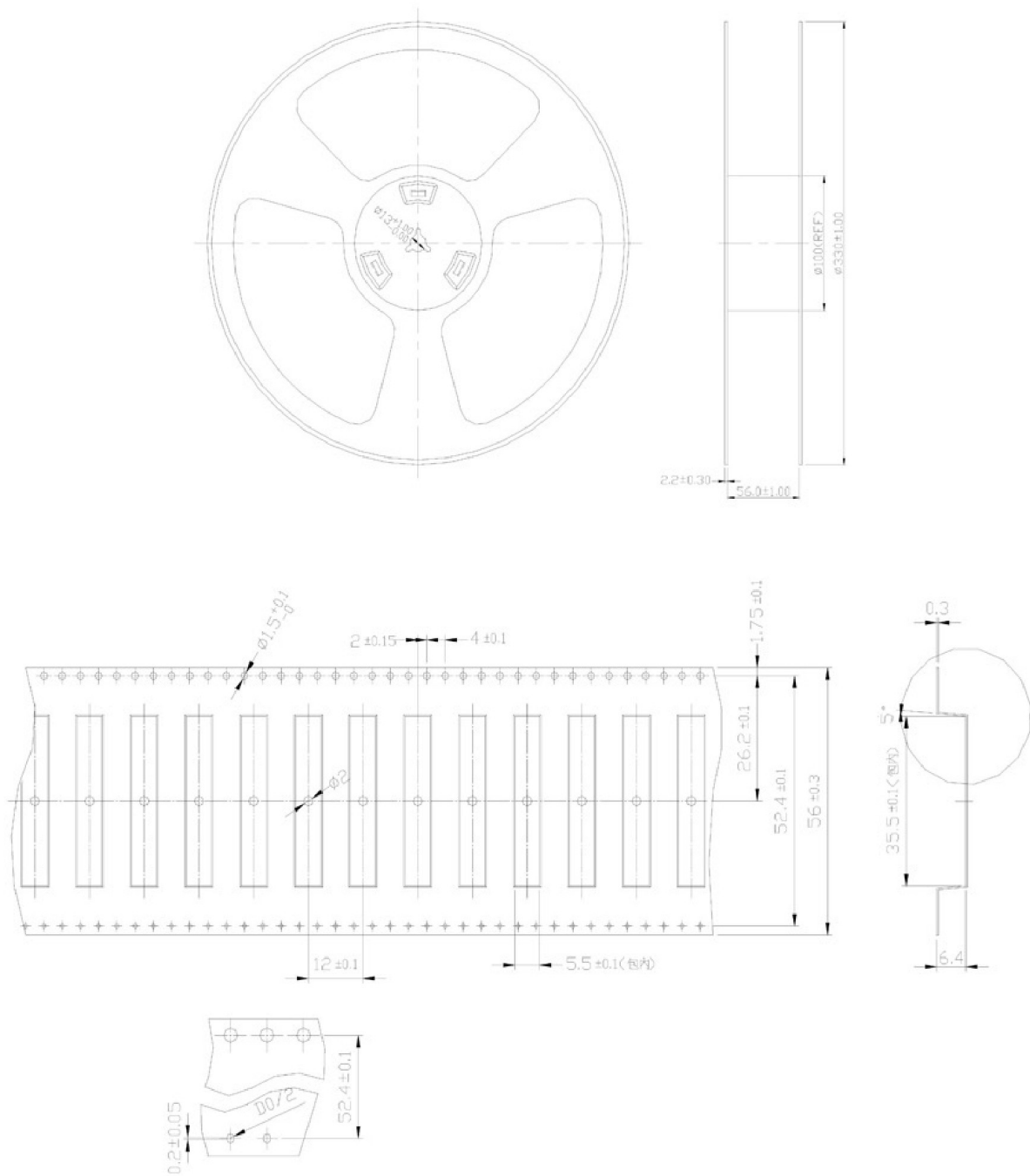

孔徑放大圖S=2/1

11.Recommended Reflow Temperature Profile

Chinmore GA-035 Planer Inverted-F antenna can be assembled following either Sn-Pb or Pb-free assembly. According to the Standard **IPC/JEDEC J-STD-020C**, the temperature profile suggested is as follow:

| Phase | Profile features | Sn-Pb Assembly | Pb-Free Assembly (SnAgCu) |
|------------------------------------|---|----------------------------------|----------------------------------|
| RAMP-UP | Avg. Ramp-up Rate (T _{smax} to TP) | 3°C/second (max) | 3°C/second(max) |
| PREHEAT | -Temperature Min(T _{Smin}) -Temperature Max(T _{Smin}) -Time(tsmin to tsmax) | 100°C 150°C 60-120 seconds | 100°C 150°C 60-120 seconds |
| REFLOW | -Temperature(TL) -Total Time above TL (t L) | 183°C 60-150 seconds | 217°C 60-150 seconds |
| PEAK | -Temperature(TP) -Time(tp) | 235°C 10-30 second | 260°C 20-40 second |
| RAMP-DOWN | Rate | 6°C / second max. | 6°C / second max. |
| Time from 25°C to Peak Temperature | | 6 minutes max. | 8 minutes max. |

Next graphic shows temperature profile(gray zone)for the antenna assembly process in reflow ovens.

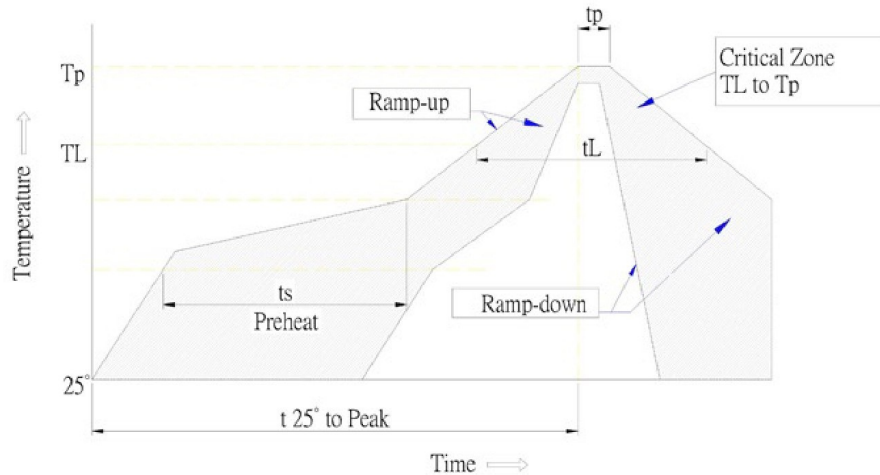

Temperatures profile